

NUTS

ALLEN

12-Point Socket

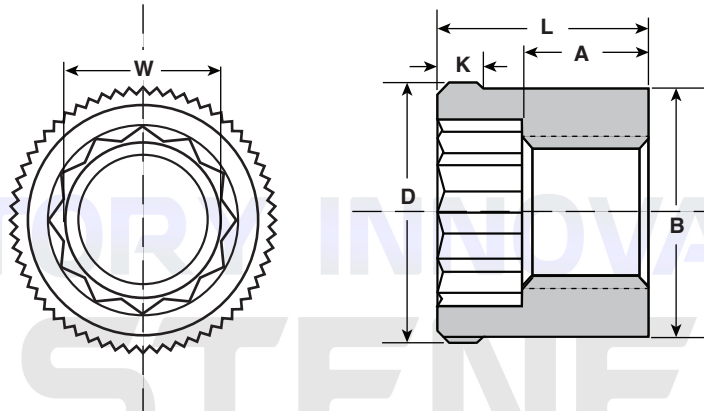

ALLEN NUTS, 12-POINT SOCKET

Nominal Nut Size	B		L		D		W	A	K
	Body Diameter		Overall Length		Knurled Diameter		Socket Width Across Flats	Threaded Length	Knurled Length
	Max	Min	Max	Min	Max	Min	Nominal	Min	Min
4	0.187	0.183	0.179	0.172	0.209	0.205	1/8	0.080	0.046
5	0.187	0.183	0.205	0.198	0.209	0.205	1/8	0.095	0.056
6	0.257	0.253	0.230	0.223	0.278	0.274	5/32	0.100	0.071
8	0.280	0.275	0.273	0.266	0.307	0.302	3/16	0.125	0.084
10	0.307	0.302	0.319	0.309	0.366	0.331	3/16	0.170	0.096
1/4	0.403	0.398	0.419	0.409	0.430	0.425	1/4	0.225	0.136
5/16	0.498	0.493	0.522	0.512	0.526	0.521	5/16	0.285	0.165
3/8	0.590	0.585	0.621	0.606	0.620	0.615	3/8	0.325	0.195
7/16	0.710	0.705	0.733	0.718	0.743	0.738	7/16	0.360	0.235
1/2	0.800	0.795	0.836	0.821	0.841	0.836	1/2	0.445	0.265
5/8	0.986	0.980	1.010	0.995	1.040	1.034	5/8	0.500	0.325
3/4	1.158	1.152	1.185	1.170	1.215	1.209	3/4	0.600	0.385
7/8	1.361	1.355	1.358	1.343	1.430	1.424	7/8	0.700	0.445
1	1.533	1.527	1.532	1.517	1.620	1.612	1	0.818	0.495

Description	A cylindrically-shaped internally threaded fastener with a knurled edge that runs completely around the outer circumference at one end of the nut. The inside of the nut is (a) threaded at one end to accept a bolt or screw, and (b) a symmetrical 12-pointed drive at the opposite end that can accept a hexagonal socket or "allen" wrench.	
Applications/ Advantages	Allen nuts are used (a) when limited space is available that prohibits external wrenching; (b) where an unassuming, low-profile look is preferred; or (c) where it's critical to apply precise amounts of torque to complete the fastening. Steel allen nuts provide greater strength than stainless nuts. Stainless nuts offer greater resistance to environmental corrosion.	
Material	<p>Steel</p> <p>Oil quenched alloy steel which conforms to the following chemical composition requirements (heat analysis)-- Carbon: 0.40% min; Manganese: 1.00% max; Phosphorus: 0.04% max; Sulfur: 0.05% max; Silicon: 0.40% max.</p>	<p>Stainless</p> <p>Austenitic stainless steel</p>
Core Hardness	Rockwell C24 - C38	-
Proof Load	150,000 psi.	-
Plating	Thermal or chemical black oxide	Nuts are typically provided without secondary finish.