

Serrated Hex Washer
Type AB & B

THREAD FORMING

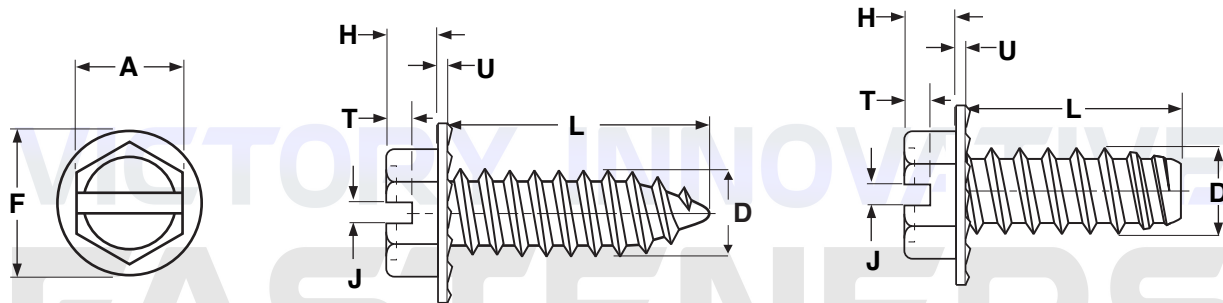

SERRATED HEX WASHER SELF TAPPING SCREWS - TYPE-AB / B

Nominal Size & Number of Threads per Inch	A		H		F		U		J		T		D		Drive Test Results				
	Width Across Flats		Head Height		Washer Diameter		Washer Thickness		Slot Width		Slot Depth		Major Diameter		Test Plate		Drive Torque	Strip Torque	Strip to Drive Ratio
	Max	Min	Max	Min	Max	Min	Max	Min	Max	Min	Max	Min	Max	Min	Hole Diam.	Thickness			
4-24	.188	.181	.060	.049	.243	.225	.019	.011	.039	.031	.036	.025	.114	.108	-	-	-	-	-
6-20	.250	.244	.093	.080	.328	.302	.025	.015	.048	.039	.046	.033	.139	.132	.081	.025	5	20	4.0:1
8-18	.250	.244	.110	.096	.348	.322	.031	.019	.054	.045	.066	.052	.166	.159	.090	.025	6.6	31	4.7:1
10-16	.312	.305	.120	.105	.414	.384	.031	.019	.060	.050	.072	.057	.189	.182	.110	.025	10	56	5.6:1
12-14	.312	.305	.155	.139	.432	.398	.039	.022	.067	.056	.093	.077	.215	.208	.187	.125	47	139	3.0:1
1/4-14	.375	.367	.190	.172	.520	.480	.050	.030	.075	.064	.101	.083	.246	.237	.2615	.125	37	148	4.0:1
5/16-12	.500	.489	.230	.208	.676	.624	.055	.035	.084	.072	.134	.100	.315	.306					
3/8-12	.562	.551	.295	.270	.780	.720	.063	.037	.094	.081	.168	.131	.380	.371					
Tolerance on Length		Up to 1" Incl.: ±0.03										Over 1": ±0.05							

Description	A slotted hex washer head thread forming tapping screw with serrations on the underside of the washer face and spaced threads. The Type-AB screw has a gimlet point while the Type-B has a blunt point.	
Applications/ Advantages	The serrations on the underside of the washer face allow this part to perform two main functions: (1) act as a locking fastener, and (2) break drive torque during installation which lessens the chance of reaming out the mating hole in the bearing surface. The torque-breaking feature slows the rotation of the screw when it meets the mating surface. The serrations allow for more pitch body diameter under the head giving the mating sheet metal more travel so as not to snap over the last bit of major diameter thread crest. Appliance manufacturers use these screws to reduce the thickness of the sheet metal they require, which reduces the cost of production.	
Material (Steel only)	AISI 1016 - 1024 or equivalent steel.	18-8 stainless steel
Heat Treatment (Steel only)	Screws shall be quenched in liquid and then tempered by reheating to 650°F minimum.	-
Surface Hardness	Rockwell C45 minimum	-
Case Depth (Steel only)	No. 6 diameter: .002 - .007 No. 8 thru 12 diameter: .004 - .009 1/4" diameter: .005 - .011	-
Core Hardness (after tempering)	Rockwell C28 - 38	-
Plating	See Appendix-A for plating information.	