

ROUND THREADED, FEMALE STANDOFFS

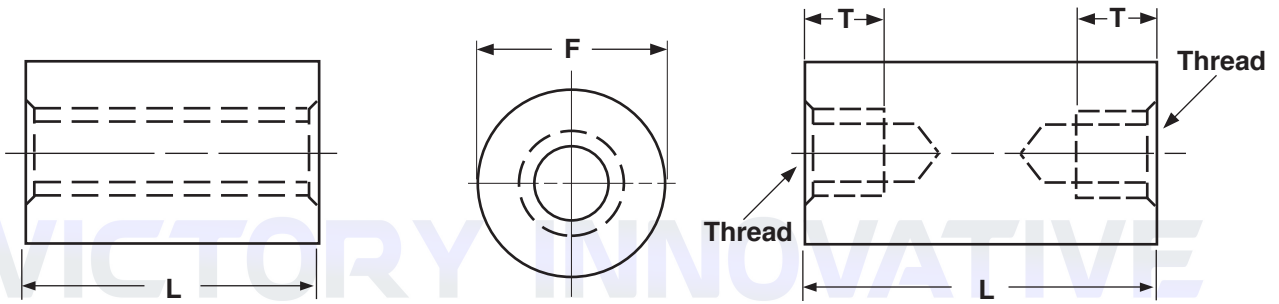

ROUND STANDOFFS									
F	Thread Size	T			F	Thread Size	T		
Outside Diameter (± 1/64)		Thread Depth		Blind Tap Depth	Outside Diameter (± 1/64)		Thread Depth		Blind Tap Depth
		Tapped Through		All Materials Min			Tapped Through		All Materials Min
		Alum, Brass, Steel	Stainless				Alum, Brass, Steel	Stainless	
1/8	2-56	3/4	5/8	3/16	3/8	6-32	1	1	3/8
3/16	2-56	3/4	5/8	3/16	3/8	8-32	1	1	7/16
3/16	4-40	1	3/4	1/4	3/8	10-32	1-1/8	1	1/2
1/4	2-56	3/4	5/8	3/16	1/2	6-32	1	1	3/8
1/4	4-40	1	3/4	1/4	1/2	8-32	1	1	7/16
1/4	6-32	1	1	3/8	1/2	10-32	1-1/8	1	1/2
1/4	8-32	1	1	7/16	1/2	1/4-20	1-1/4	1-1/4	5/8
1/4	10-32	1-1/8	1	1/2	5/8	8-32	1	1	7/16
5/16	4-40	1	3/4	1/4	5/8	10-32	1-1/8	1	1/2
5/16	6-32	1	1	3/8	5/8	1/4-20	1-1/4	1-1/4	5/8
5/16	8-32	1	1	7/16	5/8	5/16-18	1-1/4	1-1/4	5/8
5/16	10-32	1-1/8	1	1/2	5/8	3/8-16	1-1/4	1-1/4	5/8
Tolerance on Length (up to 4 in.)		Nylon parts: ±.015			All other materials: ±.005				

Description	A cylindrical, mechanical device which has a partial or complete internal thread, used to hold two components at a given distance from each other.
Applications/ Advantages	Standoffs are usually chosen over spacers when longer sizes are required. Round standoffs are less common than hex, used in applications where wrenching of the standoff is not required. Aluminum is popular for its light weight/ strength compromise. It is non-magnetic, performs well in severe temperatures, and has insulating properties. Nylon is a good insulator and has a surface smoothness which will not fray the insulation of wires that rub against it. Its threads will withstand torque without stripping. Brass is used in making high-quality standoffs. It is conductive, resists corrosion, and is non-magnetic. It is costlier and heavier than aluminum and is usually plated zinc or nickel. Stainless has the advantages of brass but has superior resistance to corrosion and chemical fumes. Steel is used in applications requiring greater strength, but it is heavier than aluminum and does not resist corrosion like aluminum or brass.
Material	<p>Aluminum: 2011 Aluminum (Copper: 5.0-6.0%; Silicon: 0.4% maximum; Iron: 0.7% maximum; Zinc: 0.3% maximum; Bismuth: 0.2-0.6%; Lead: 0.2-0.6%)</p> <p>Nylon: Nylon 6/6</p> <p>Brass: C36000 Brass (Copper: 60.00-63.00%; Lead: 2.50-3.70%; Iron: .35% maximum)</p> <p>Stainless: 303 stainless, passivated to ASTM A 380</p> <p>Steel: 12L14 Steel-Leaded Grade A (Carbon: .15% maximum; Manganese: .85-1.15%; Phosphorus: .04-.09%; Sulphur: .26-.35%)</p>