

# RIVETS

## TRUSS HD DRIVE PIN ANCHOR RIVET

All Nylon  
Nylon / Steel

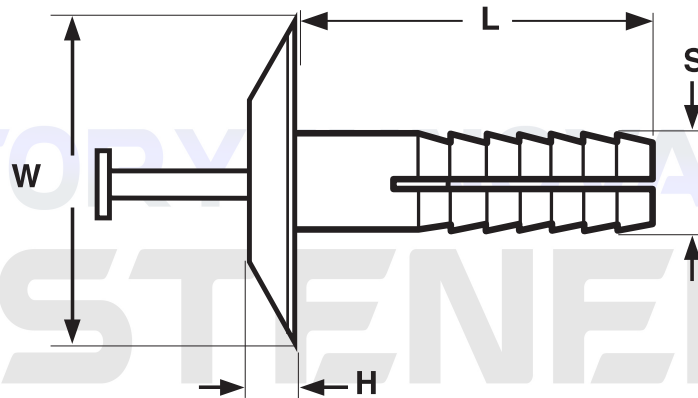

VICTORY INNOVATIVE  
FASTENERS  
YOUR GLOBAL FASTENER SOURCE

TWO PIECE DRIVE PIN ANCHOR RIVETS, TRUSS HEAD						
Nominal Diameter	W		H		S	
	Head Width		Head Height		Shank Diameter	
	Max	Min	Max	Min	Max	Min
10	.630	.620	.115	.105	.203	.173
1/4	.630	.620	.115	.105	.265	.235
Tolerance on Length			+/- .015			

<b>Description</b>	A fastening system which consists of two parts: (1) a nylon component which has a cylindrical shank split on two sides, 180° apart, extending from the bottom of the shank up most of the distance to the head. The shank has several ribs extending completely around its circumference. Truss head style has a low profile, trapezoidal-shaped head and is approximately 2.5 to 3.3 times the diameter of the shank. (2) a pin expander (which may be steel or nylon) which passes through a concentric channel extending from an opening in the top of the head of the nylon piece down into the shank to a point just below the spot where the split ends below the head. The steel pin has a slot across the top of its head, a chiseled point similar to a nail, and threads on its own shank which helps to lock the anchor in place upon installation. The nylon pin has a smooth, flat top and smooth shank.
<b>Applications/ Advantages</b>	An economical multipurpose blind fastener for use in predrilled hole and installed with a hammer. Provides resistance to electrical conductivity, vibration and corrosion. Can be used in floor plates, truck trailers, plumbing fixtures, window/drapery hardware and storage shelves. The truss head variety is preferred where minimal clearance exists above the head. Steel pin variety offers greater pull-out strength.
<b>Material</b>	<b>All Plastic style:</b> Nylon 6/6 impact modified <b>Plastic Rivet/Steel Pin style:</b> Rivet- Nylon 6/6 impact modified, Pin- Carbon Steel w/ Zinc Plate
<b>Melting Point</b>	500° F