

Hex & Square **MACHINE SCREW**

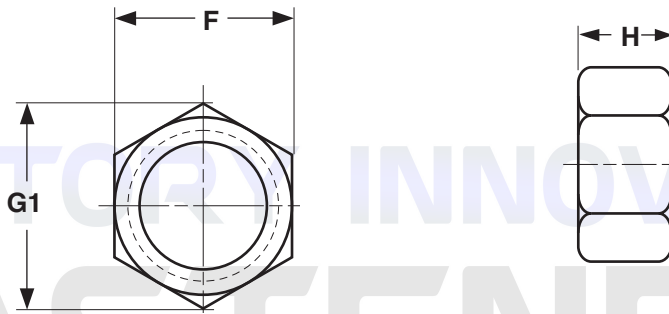

VICTORY INNOVATIVE FASTENERS  
YOUR GLOBAL FASTENER SOURCE

SMALL PATTERN HEX MACHINE SCREW NUTS									Based on ASME B18.2.2
Nominal Size or Basic Thread Diameter		F			G1		H		
		Width Across Flats			Width Across Corners		Thickness		
		Basic	Max	Min	Max	Min	Max	Min	
4	0.1120	3/16	0.188	0.180	0.217	0.205	0.066	0.057	
5	0.1250	1/4	0.250	0.241	0.289	0.275	0.098	0.087	
6	0.1380	1/4	0.250	0.241	0.289	0.275	0.098	0.087	
8	0.1640	1/4	0.250	0.241	0.289	0.275	0.098	0.087	
8	0.1640	5/16	0.312	0.302	0.361	0.344	0.114	0.102	
10	0.1900	1/4	0.250	0.241	0.289	0.275	0.098	0.087	
10	0.1900	5/16	0.312	0.302	0.361	0.344	0.114	0.102	

VICTORY INNOVATIVE FASTENERS  
YOUR GLOBAL FASTENER SOURCE

<b>Description</b>	Similar in design to standard hex machine screw nuts but with smaller widths across the flats and across the corners.
<b>Applications/Advantages</b>	Designed to be used with machine screws in areas where there is limited space for wrenching. Stainless nuts are used with stainless machine screws where parts are subject to corrosive conditions.
<b>Material</b>	<i>Steel:</i> Any low carbon steel <i>Stainless:</i> 18-8 stainless steel
<b>Plating</b>	See Appendix-A for information about the plating of steel machine screw nuts..