

PLOW BOLTS

#3 Head

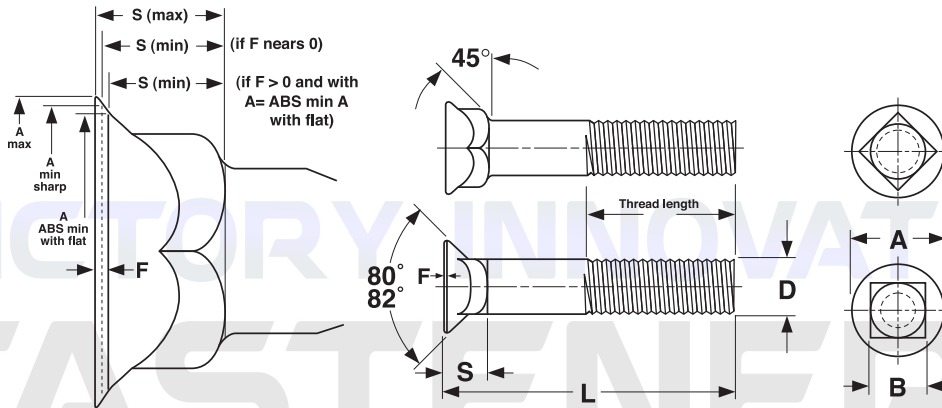

†Length of a plow bolt is measured from the top of the head to the extreme end of the bolt.

No. 3 HEAD PLOW BOLTS

ASME B18.9-2012

Nominal Diameter	Diameter of Full Size Body		Diameter of Head			Feed Thickness	Depth of Square and Head		Width of Square	
	Max	Min	Max	Min Sharp	Abs. Min with Flat	Max	Max	Min	Max	Min (Basic)
5/16	0.312	0.299	0.605	0.578	0.538	0.040	0.269	0.228	0.325	0.313
3/8	0.375	0.360	0.708	0.671	0.624	0.050	0.312	0.262	0.387	0.375
7/16	0.438	0.421	0.826	0.781	0.729	0.058	0.364	0.306	0.450	0.438
1/2	0.500	0.483	0.945	0.890	0.831	0.068	0.417	0.349	0.515	0.500
5/8	0.657	0.606	1.147	1.094	1.013	0.080	0.506	0.426	0.640	0.625
3/4	0.782	0.729	1.303	1.250	1.169	0.080	0.541	0.461	0.765	0.750
7/8	0.938	0.853	1.512	1.469	1.469	0.100	0.626	0.526	0.906	0.875
1	1.062	0.976	1.700	1.656	1.656	0.100	0.690	0.590	1.031	1.000

Tolerance on Length	Nominal Bolt Size	All Lengths
	1/4 through 3/8	±0.03
	7/16 and 1/2	±0.06
	5/8 through 1	±0.12

MINIMUM THREAD LENGTH OF PLOW BOLTS (2D + 0.25)

ASME B18.9-2012

Recommended Bolt Length	Nominal Bolt Diameter, D							
	5/16	3/8	7/16	1/2	5/8	3/4	7/8	1
1	T to H	T to H	-	-	-	-	-	-
1-1/4	0.875	T to H	T to H	T to H	T to H	-	-	-
1-1/2	0.875	1.000	T to H	T to H	T to H	T to H	T to H	-
1-3/4	0.875	1.000	1.125	1.250	T to H	T to H	T to H	T to H
2	0.875	1.000	1.125	1.250	T to H	T to H	T to H	T to H
2-1/4	0.875	1.000	1.125	1.250	1.500	T to H	T to H	T to H
2-1/2	0.875	1.000	1.125	1.250	1.500	1.750	T to H	T to H
3	0.875	1.000	1.125	1.250	1.500	1.750	2.000	2.250
3-1/2	0.875	1.000	1.125	1.250	1.500	1.750	2.000	2.250
4	0.875	1.000	1.125	1.250	1.500	1.750	2.000	2.250

"T to H" = Threaded to Head or square within 2.5 full threads.

Grades 5 & 8 **PLOW BOLTS**

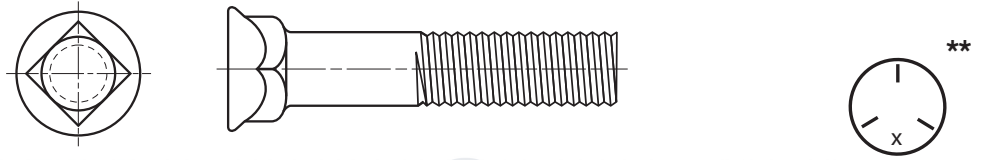

GRADE-5 PLOW BOLT

Description	Bolt with a countersunk, flat head, square neck and unified thread pitch, made from medium-carbon steel.
Applications/ Advantages	Used in road graders, scoop shovels and other heavy-duty equipment where a smooth surface is required at the spot of head protrusion.
Material	Grade-5 Plow Bolts shall be made from a medium carbon steel which conforms to the following chemical composition requirements: <i>Carbon:</i> 0.28% to 0.55%; <i>Phosphorus:</i> 0.048% maximum; <i>Sulphur:</i> 0.058% maximum.
Heat Treatment	Grade-5 Plow Bolts shall be heat treated, oil or water quenched, and tempered at a minimum tempering temperature of 800°F.
Core Hardness	Rockwell C25 - C34
Surface Hardness	Rockwell 30N 54 maximum
Proof Load	85,000 psi.
Yield Strength	92,000 psi. minimum
Tensile Strength	120,000 psi. minimum
Plating	See Appendix-A for plating information.

GRADE-8 PLOW BOLT



Description	A plow bolt made from alloy steel.
Applications/ Advantages	Greater tensile and proof load strength than a grade-5. Popular use is with bulldozer and snowplow blades.
Material	AISI 4037 and 4042 steel
Heat Treatment	Grade-8 Plow Bolts shall be heat treated, oil quenched and tempered at a minimum tempering temperature of 800°F.
Core Hardness	Rockwell C33 - C39
Surface Hardness	Rockwell 30N58.6 maximum
Proof Load	120,000 psi.
Yield Strength	130,000 psi. minimum
Tensile Strength	150,000 psi. minimum
Plating	Bolts are supplied unplated.

**Product standards require the manufacturer's head marking to appear on the top of all bolts 1/4" diameter and larger. "X" represents one location such a marking may appear.